

166 HALF-CELL SERIES

Multiple Upgrades Were Forged Into One

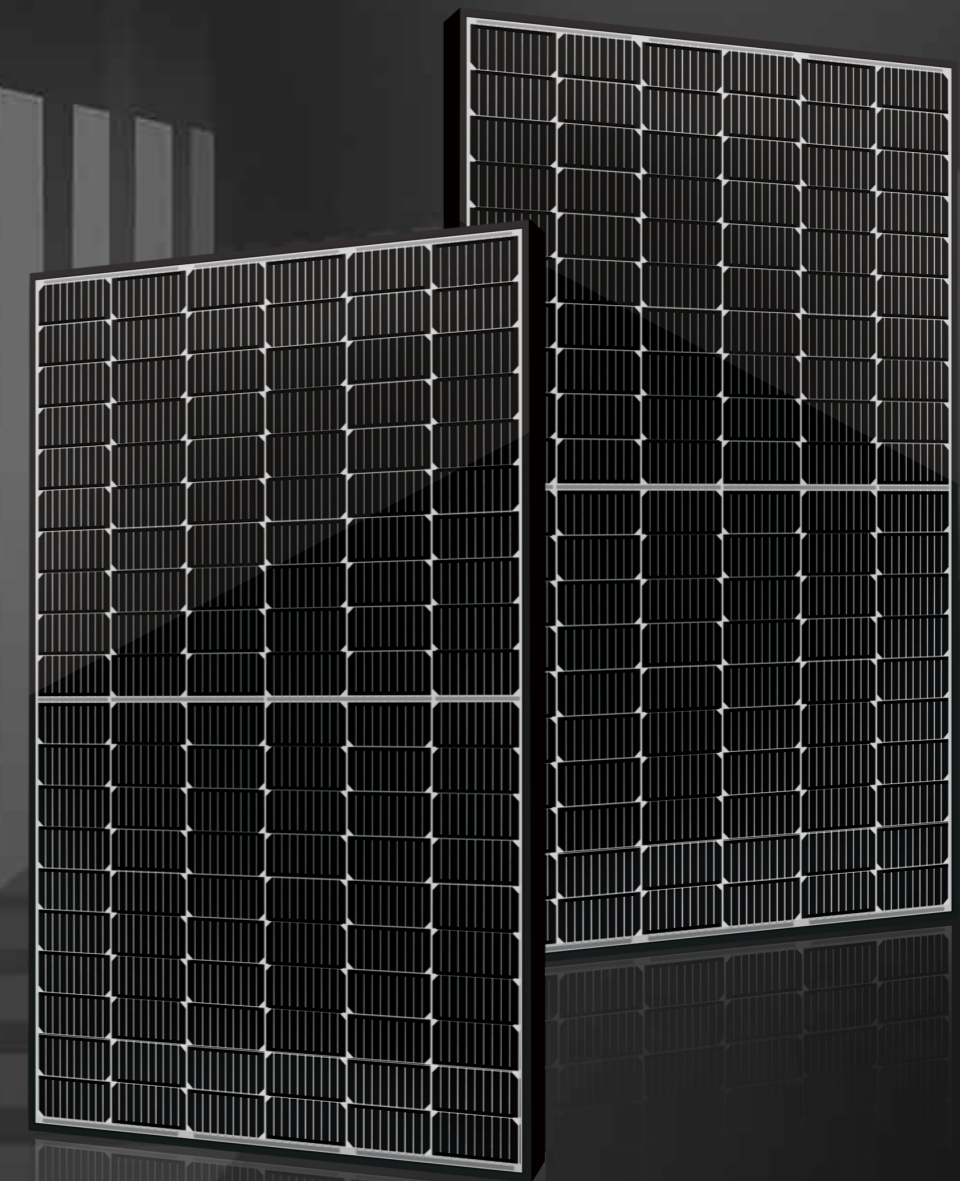

360W–375W



166 Half-Cell Series – The Amalgamation Of Advanced Technologies

Seraphim redefined the high-efficiency module series by integrating 166mm silicon wafers with multi-busbar and half-cut cell technologies. The maximum module efficiency of the new 166 half-cell series is 20%, and the maximum power output is 375W.

Less Mismatch Loss

Instead of 6 internal strings of cells, the 166 HALF-CELL series module has 2 x 6 shorter ones. This design effectively deals with the mismatch happened between cells caused by shadow, out of sync performance degradation, ect.

Less Internal Power Loss

The ribbon length of half-cell is shorter than normal cell. Calculated by Joule's law and Ohm' law, the power loss reduction is nearly 6%.

Product Certificates



Insurance



Warranty

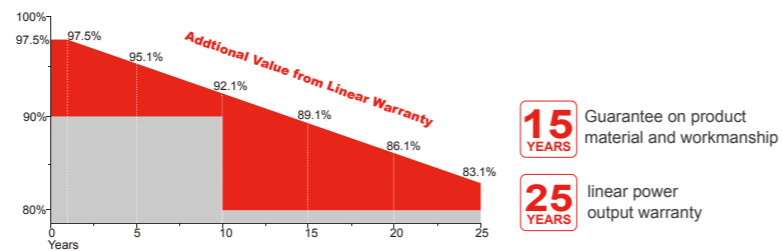

More Benefits

- Higher module conversion efficiency up to 20%
- Outstanding performance at low irradiance
- Less mismatch and parallel design reduce shading impact
- Excellent temperature dependent performance
- Lower risk of hot spot effects
- Significantly lower LCOE, and BoS cost savings

More Energy Yield, Less System CAPEX

Affected by a significant increase in product power, the application of the new 166 half-cell series in large commercial and utility power stations can significantly reduce LCOE, BOS, EPC and land costs. Projects over 1MW can save at least 5% CAPEX per watt by using new 166 half-cell series modules instead of standard modules.

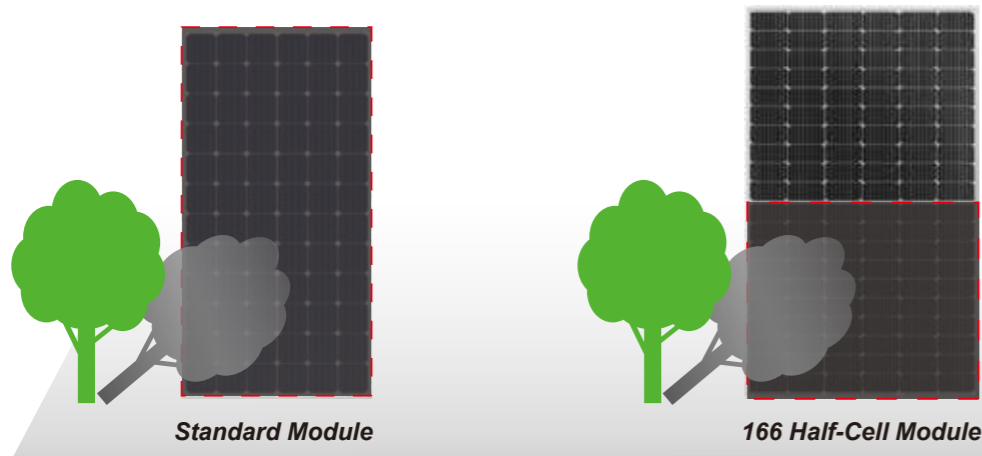

Electrical Characteristics

Module Type	SRP-360-BMB	SRP-365-BMB	SRP-370-BMB	SRP-375-BMB
	STC	STC	STC	STC
Maximum Power at STC (Pmp)	360	365	370	375
Open Circuit Voltage (Voc)	41.2	41.4	41.6	41.8
Short Circuit Current (Isc)	11.16	11.26	11.34	11.41
Maximum Power Voltage (Vmp)	34.2	34.4	34.6	34.8
Maximum Power Current (Imp)	10.53	10.62	10.70	10.78
Module Efficiency at STC(ηm)	19.27	19.54	19.80	20.07
Power Tolerance	(0,+4.99)			
Maximum System Voltage	1000 VDC			
Maximum Series Fuse Rating	20A			

STC: Irradiance 1000 W/m² module temperature 25°C AM=1.5;

Temperature Characteristics

Pmax Temperature Coefficient	-0.36 %/°C
Voc Temperature Coefficient	-0.28 %/°C
Isc Temperature Coefficient	+0.05 %/°C
Operating Temperature	-40 ~ +85 °C
Nominal Operating Cell Temperature (NOCT)	45±2 °C

Mechanical Specifications

External Dimensions	1776 x 1052 x 35 mm
Weight	20.0kg
Solar Cells	PERC Mono (120pcs)
Front Glass	3.2 mm AR coating tempered glass, low iron
Frame	Anodized aluminium alloy
Junction Box	IP68,3 diodes
Output Cables	4.0 mm ² , Portrait:255mm(+)/355mm(-); Landscape:1300mm
Connector	MC4 Compatible
Mechanical Load	Front side 5400Pa/ Rear side 2400Pa

Packing Configuration

	1776 x 1052 x 35 mm		
Container	20'GP	40'GP	40'HQ
Pieces per Pallet	30	30	30+1*
Pallets per Container	6	24	24
Pieces per Container	180	720	744

* 27+1 pieces per pallet is the special package which only suits for container transport. For details, please consult SERAPHIM.

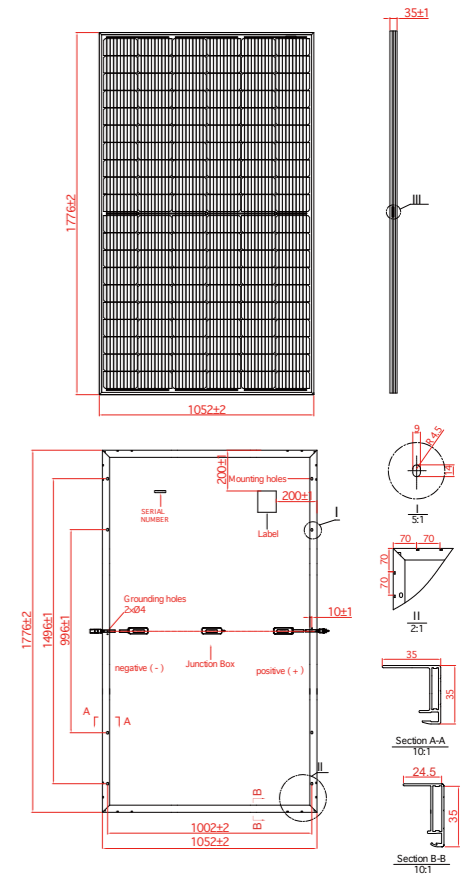

I-V Curve

