



GCL-P6/60

HIGH EFFICIENCY
MULTICRYSTALLINE MODULE

GCL-P6/60 250-265 Watt

265^W

MAXIMUM POWER OUTPUT

16.3%

MAXIMUM MODULE EFFICIENCY

25^{YEARS}

LINEAR POWER WARRANTY

Trust GCL to Deliver Reliable Performance Over Time

- World-class manufacturer of crystalline silicon photovoltaic modules
- Fully automatic facility and world-class technology
- Rigorous quality control to meet the highest standard: ISO9001:2008, ISO 14001: 2004 and OHSAS: 18001 2007
- Tested for harsh environments (salt mist, ammonia corrosion and sand blowing test: IEC 61701, IEC 62716, DIN EN 60068-2-68)
- Long term reliability tests
- 2*100% EL inspection ensuring defect-free modules

LINEAR PERFORMANCE WARRANTY

10 YEARS PRODUCT WARRANTY

25 LINEAR POWER WARRANTY

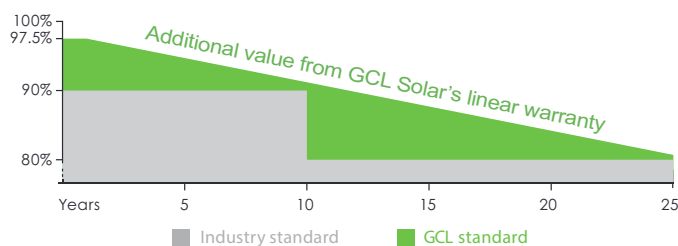

High conversion efficiency due to top quality wafer and advanced cell technology



PID and snail trails free



Highly resistant to sand, acid, and alkali



Optimized system performance by module level current sorting



Excellent performance under low irradiance



Additional yield and easy maintenance with high transparent self-cleaning glass

Additional insurance backed by Swiss RE



Bringing Green Power to Life

GCL-P6/60

HIGH EFFICIENCY MULTICRYSTALLINE MODULE

ELECTRICAL SPECIFICATION (STC)

Peak Power Watts	Pm(W)	250	255	260	265
Power Output Tolerance	Pm(W)	±5			
Maximum Power Voltage	Vm(V)	30.4	30.6	30.8	31.0
Maximum Power Current	Im(A)	8.22	8.33	8.44	8.55
Open Circuit Voltage	Voc(V)	37.7	37.7	37.9	38.1
Short Circuit Current	Isc(A)	8.86	8.98	9.09	9.20
Module Efficiency	(%)	15.4	15.7	16.0	16.3

Values at Standard Test Conditions STC (Air Mass AM1.5, Irradiance 1000W/m², Cell Temperature 25° C).

ELECTRICAL DATA (NOCT)

Maximum Power	Pm(W)	183.6	185.2	189.3	192.5
Power Output Tolerance	Pm(W)	±5			
Maximum Power Voltage	Vm(V)	27.2	27.4	27.6	27.7
Maximum Power Current	Im(A)	6.75	6.76	6.86	6.95
Open Circuit Voltage	Voc(V)	34.5	34.7	34.9	35.1
Short Circuit Current	Isc(A)	7.21	7.28	7.37	7.45

NOCT: Irradiance at 800W/m², Ambient Temperature 20° C, Wind Speed 1m/s.

MECHANICAL DATA

Solar Cells	Poly 156x156mm (6 inches)
Cell Orientation	60 Cells (6x10)
Module Dimensions	1640x992x40mm (64.56 x 39.05 x 1.57 inches)
Weight	18.5KG
Glass	High transparency solar glass 3.2mm (0.13 inches)
Backsheet	White
Frame	Silver, anodized aluminium alloy
J-Box	IP67 Rated
Cables	4.0mm ² (0.006 inches ²), 900mm (35.4 inches)
Connector	Original MC4 or Compatible

TEMPERATURE RATINGS

Nominal Operating Cell Temperature (NOCT)	45±2°C
Temperature Coefficient of P _{MAX}	-0.43% /°C
Temperature Coefficient of V _{OC}	-0.35% /°C
Temperature Coefficient of I _{SC}	0.04% /°C

MAXIMUM RATINGS

Operational Temperature	-40~+85°C
Maximum System Voltage	1000V DC(IEC)
Max Series Fuse Rating	15A

WARRANTY

10 years Product Workmanship Warranty
25 years linear Power Warranty

(Please refer to GCL standard warranty for details)

PACKAGING CONFIGURATION

Modules per box: 26 pieces
Modules per 40' container: 728 pieces

MODULE DIMENSION

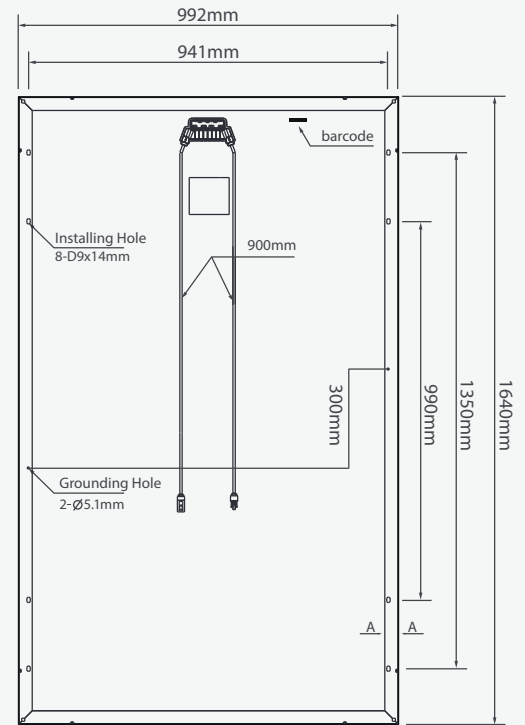

Back View

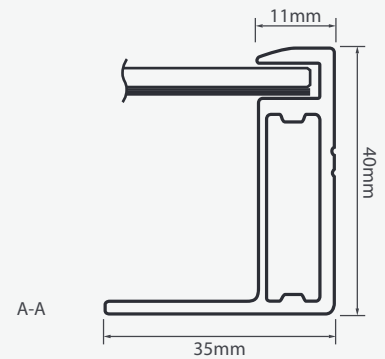

I-V CURVES OF MODULE (260W)

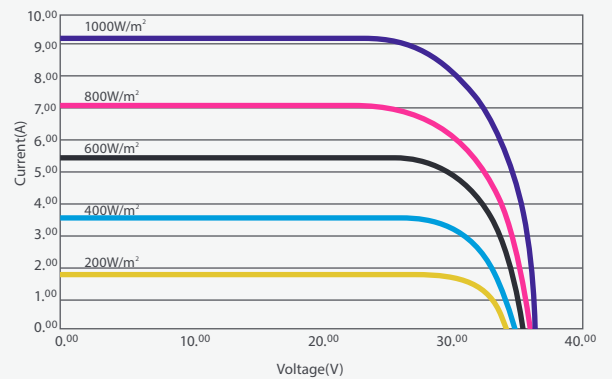

Excellent performance under weak light conditions: at an irradiance intensity of 200W/m² W/m(AM 1.5, 25°C), 96.5% or higher of the STC efficiency (1000 W/m²) is achieved



Bringing Green Power to Life
<http://en.gclsi.com>

GCL-EN-P6/60-2016-V1.0

CAUTION: READ INSTALLATION MANUAL BEFORE USING THE PRODUCT

©2015 GCL System Intergration Technology Co., Ltd. All rights reserved. Specifications included in this datasheet are subject to change without notice.