

20% EFFICIENCY

SunPower E20 panels are the highest efficiency panels on the market today, providing more power in the same amount of space

TRANSFORMERLESS INVERTER COMPATIBILITY

Comprehensive inverter compatibility ensures that customers can pair the highest-efficiency panels with the highest-efficiency inverters, maximizing system output

POSITIVE POWER TOLERANCE

Positive tolerance ensures customers receive the rated power or higher for every panel

RELIABLE AND ROBUST DESIGN

SunPower's unique Maxeon™ cell technology and advanced module design ensure industry-leading reliability



THE WORLD'S STANDARD FOR SOLAR™

SunPower™ E20 Solar Panels provide today's highest efficiency and performance. Powered by SunPower Maxeon™ cell technology, the E20 series provides panel conversion efficiencies of up to 20.4%. The E20's low voltage temperature coefficient, anti-reflective glass and exceptional low-light performance attributes provide outstanding energy delivery per peak power watt.

SUNPOWER'S HIGH EFFICIENCY ADVANTAGE

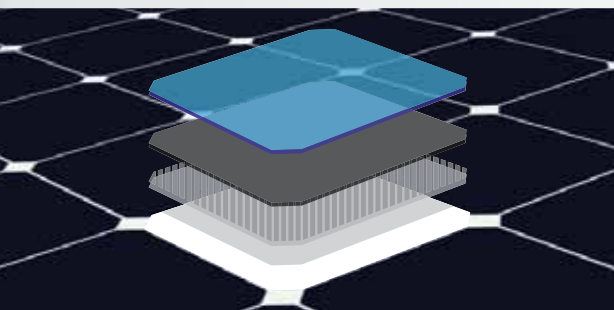
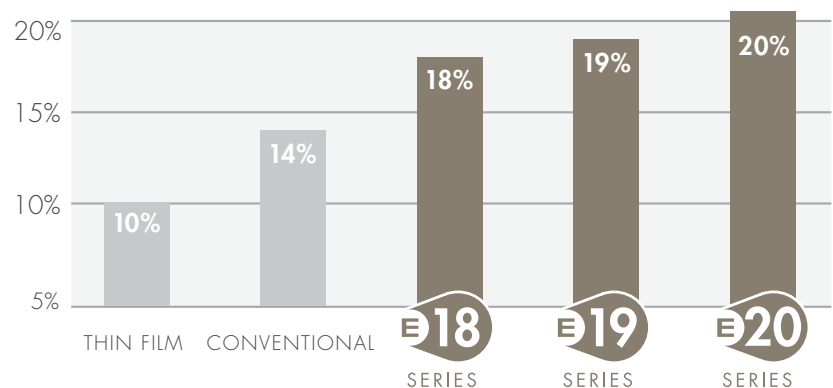

MAXEON™ CELL TECHNOLOGY

Patented all-back-contact solar cell, providing the industry's highest efficiency and reliability.



MODELS: SPR-333NE-WHT-D, SPR-327NE-WHT-D

ELECTRICAL DATA			
Measured at Standard Test Conditions (STC): Irradiance 1000W/m ² , AM 1.5, and cell temperature 25° C			
Nominal Power (+5/-0%)	P _{nom}	333 W	327 W
Cell Efficiency	η	22.8%	22.5%
Panel Efficiency	η	20.4%	20.1 %
Rated Voltage	V _{mpp}	54.7 V	54.7 V
Rated Current	I _{mpp}	6.09 A	5.98 A
Open-Circuit Voltage	V _{oc}	65.3 V	64.9 V
Short-Circuit Voltage	I _{sc}	6.46 A	6.46 A
Maximum System Voltage	IEC	1000 V	1000 V
Temperature Coefficients	Power (P)	- 0.38%/K	
	Voltage (V _{oc})	- 176.6mV/K	
	Current (I _{sc})	3.5mA /K	
NOCT	45°C +/- 2°C		
Series Fuse Rating	20 A		
Limiting Reverse Current (3 strings)	I _r	16.2 A	
Grounding	Positive grounding not required		

ELECTRICAL DATA			
Measured at Nominal Operating Cell Temperature (NOCT): Irradiance 800W/m ² , 20° C, wind 1 m/s			
Nominal Power	P _{nom}	247 W	243 W
Rated Voltage	V _{mpp}	50.4 V	50.4 V
Rated Current	I _{mpp}	4.91 A	4.82 A
Open-Circuit Voltage	V _{oc}	61.2 V	60.8 V
Short-Circuit Voltage	I _{sc}	5.22 A	5.22 A

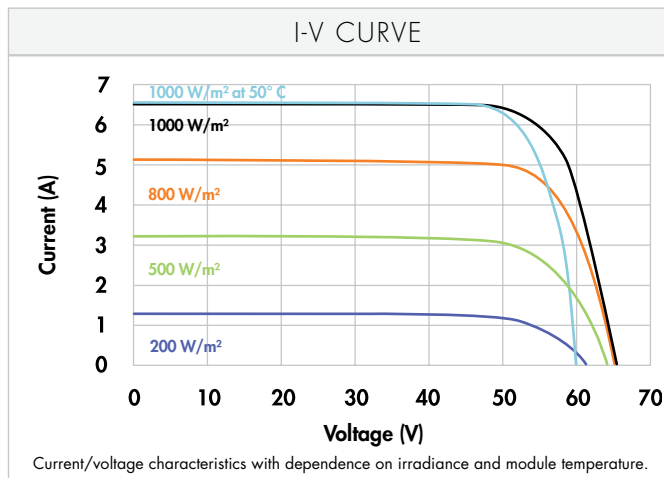

TESTED OPERATING CONDITIONS	
Temperature	- 40° C to +85° C
Max load	550 kg/m ² (5400 Pa), front (e.g. snow) w/specified mounting configurations 245 kg/m ² (2400 Pa) front and back (e.g. wind)
Impact Resistance	Hail: 25 mm at 23 m/s

WARRANTIES AND CERTIFICATIONS	
Warranties	25-year limited power warranty 10-year limited product warranty
Certifications	IEC 61215 Ed. 2, IEC 61730 (SCII)

MECHANICAL DATA			
Cells	96 SunPower Maxeon™ cells		
Front Glass	High-transmission tempered glass with anti-reflective (AR) coating		
Junction Box	IP-65 rated with 3 bypass diodes 32 x 155 x 128 mm		
Output Cables	1000 mm cables / Multi-Contact (MC4) connectors		
Frame	Anodised aluminium alloy type 6063 (black)		
Weight	18.6 kg		

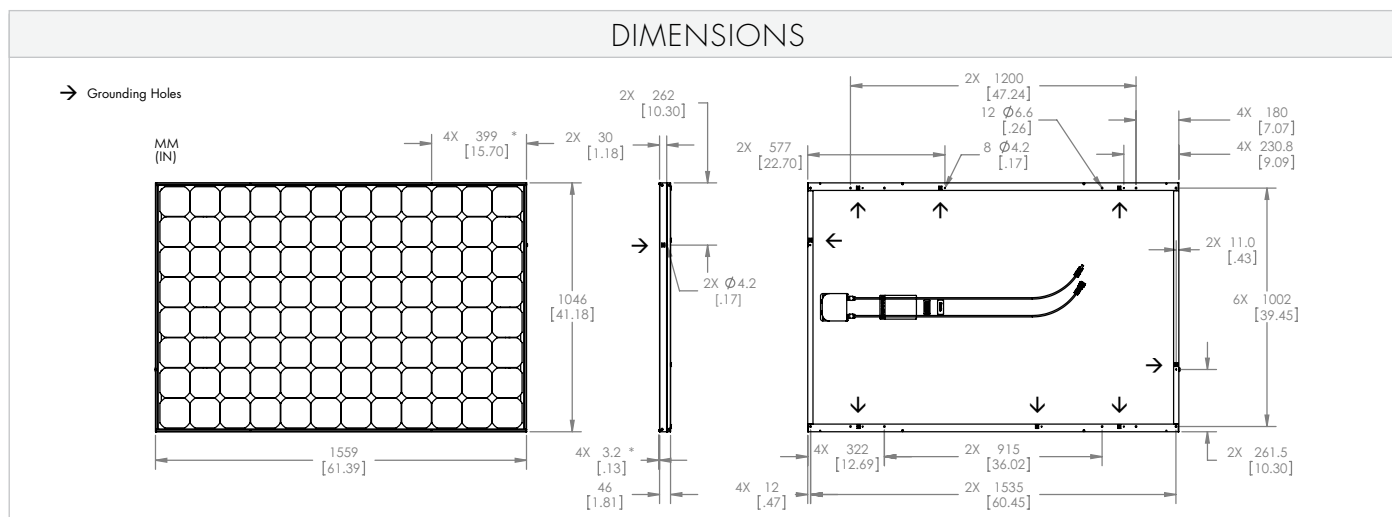

Please read safety and installation instructions before using this product, visit sunpowercorp.com for more details.